

# JIFTEK

MATERIAL HANDLING EQUIPMENTS

倉儲物流搬運設備



**LIFTEK** 是台灣第一家通過，國際知名BQR美國貝爾國際驗證機構ISO-9001品質管理制度驗證，以及台灣工業研究院工安衛中心，型式結構安全檢定合格之自走式電動推高機、自走式電動拖板車等，各式倉儲物流搬運設備之專業製造優良廠商。

**LIFTEK** 為實踐企業永續經營的理念，及強化專業負責任的服務態度，於2000年初在風景秀麗的宜蘭利澤工業區內，再斥資300萬美元資金，投資興建完成一現代化新廠房，以產銷自走式電動堆高機、自走式電動拖板車及各式倉儲物流搬運設備及其相關產品，行銷於台灣、中國大陸及歐、亞、美等各洲廣大的國際市場。

為作好相關產品之售前與售後服務業務 **LIFTEK** 除了在台灣北、中、南、東各地區，廣設多處直營或特約之營銷服務處所外，更於2001年起，陸續於中國上海、華北、華南等各主要經濟發展區域內，設立相關產品之行銷與售後服務處所，**LIFTEK** 感謝並珍惜每一個為客戶服務的機會。



**LIFTEK** Is a professional manufacturer of Electric Pallet Stackers, Electric Pallet Trucks and other Material Handling Equipments in Taiwan.

Since 1994 **LIFTEK** was founded, our persistency on quality production control has made us a reliable and good-quality maker. Today, **LIFTEK** has become the leading maker of Material Handling Equipments in Taiwan.

In order to increase our competitiveness to attain national level in terms of cost effectiveness and quality, in 1999, **LIFTEK** Invested USD three million on a new plant in I-Lan, Taiwan. And in year 2000 **LIFTEK** Was ISO-9001 certified.

**LIFTEK** will continue to strive in increasing our product range and improving our product quality, so that we can seize all possible opportunities to work with world class OEMs and distributors. **Our vision is to achieve the best in product requirement and quality satisfaction for our customers.**







伸縮式電動堆高機  
Electric Reach Forklift

2



電動堆高機  
Electric Forklift

4



自走式電動堆高機  
Electric Pallet Stacker

6



手拉式電動堆高機  
Semi-electric Pallet Stacker

9



自走式電動拖板車  
Electric Pallet Truck

10



手拉式油壓拖板車  
Hand Pallet Truck

12



手動堆高機  
Manual Pallet Stacker

13



高空取料機  
Mobile Hydraulic Picker

14



手推式昇降平台車  
Pushed Lifting Table

15



高空作業台  
Mobile Hydraulic Lifter

16

# 伸縮式電動堆高機

## Electric Reach Forklift

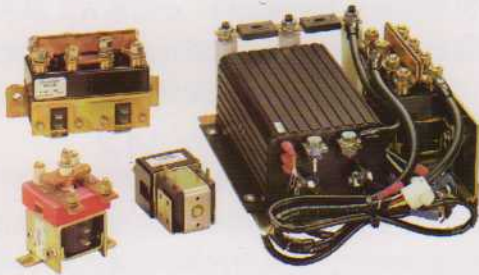

- ※無害氣、噪音污染。
- ※低設備成本，高工作效益。
- ※伸縮式桅桿設計，操作安全，省作業空間。
- ※可調式鍛造鋼貨叉，適用於單面或雙面棧板作業。
- ※採用歐美進口高品質：驅動主機、液壓系統、微電腦無段式速度控制系統等原裝零組件，品質穩定。
- ※獨特的液壓式驅動主機懸吊設計，對地磨擦力穩定，能源效率更高。
- ※配備歐洲名牌原裝大型工業電瓶，可作長時間的連續作業。

- ※ DC-24V power, no gas and noise pollution.
- ※ Compact, easy operate and maintenance.
- ※ Reach type mast designed for saving operating stacking aisle
- ※ Robust construction with high quality driving, lifting and speed controlling components, to provide the best performance.
- ※ Five points wheels touch to the ground, safety and stability in driving.
- ※ Equipped with traction batteries and automatic power charger.
- ※ Low cost and high economic efficiency.

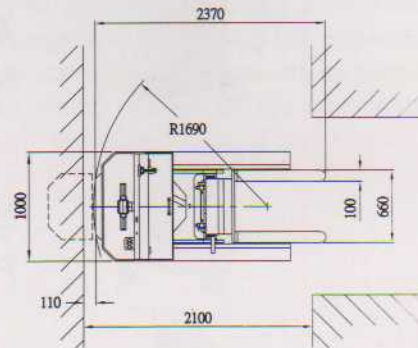
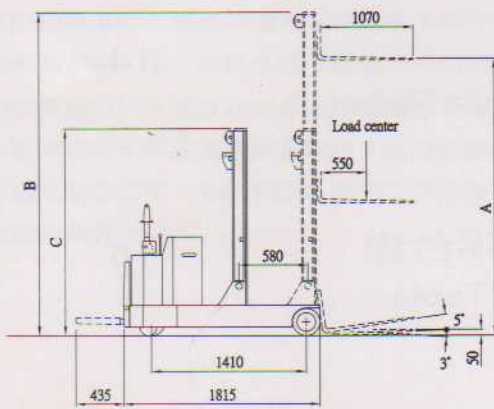



## 規格說明 Specifications

型式	Model		LPF-12SR	LPF-15SR
負載能力	Loading capacity	kg .	1200	1500
動力源	Power source		DC-24V	DC-24V
行走馬達	Driving motor	kw.	1.5	1.5
昇降馬達	Lifting motor	kw.	3.0	3.0
空載行走速度	Empty driving speed	km/h	4.5	4.5
負載行走速度	Loaded driving speed	km/h	3.5	3.5
空載爬坡能力	Empty gradient	%	8	8
負載爬坡能力	Loaded gradient	%	6	6
操作方式	Operating type		立乘式 Stand ride	立乘式 Stand ride
機台全長	Overall length	mm.	2370	2470
A 揚昇高度	Lifting height	mm.	2750	2750
B 全昇機高	Extended height	mm.	3250	3250
C 全降機高	Lowered height	mm.	1925	1925
桅桿伸縮行程	Reach/Shrink distance	mm.	580	580
貨叉傾斜角度	Fork tilting angle	degree	前傾 Forward 3° / 後仰 Backward 5°	
迴轉半徑	Turning radius	mm.	1690	1790
直角通道寬	Angle stacking aisle	mm.	2100	2200
煞車器	Brake		電磁式 Electric	電磁式 Electric
行走控制器	Driving controller		微電腦無段式 Transistor	微電腦無段式 Transistor
驅動輪	Driving wheel	mm.	230 / 75	230 / 75
負載輪	Loading wheels	mm.	230 / 70	230 / 70
輔助輪	Auxiliary wheels	mm.	150 / 50	150 / 50
電瓶	Battery	Ah/5hr.	240	240
電瓶重量	Battery weight	kg .	245	245
機台重量	Weight with battery	kg .	1900	2000
充電機	Power charger		DC-24V / 40A	DC-24V / 40A

雙節式桅桿行程尺寸表 Duplex mast

A 揚昇高度	B 全昇機高	C 全降機高
2750 st.	3250 mm.	1925 mm.
3000 st.	3500 mm.	2050 mm.
3250 st.	3750 mm.	2175 mm.
3500 st.	4000 mm.	2300 mm.

參節式桅桿行程尺寸表 Triplex mast

A 揚昇高度	B 全昇機高	C 全降機高
4000 st.	4500 mm.	1925 mm.
4500 st.	5000 mm.	2080 mm.
5000 st.	5500 mm.	2250 mm.
5500 st.	6000 mm.	2400 mm.

※為配合特殊作業功能要求，如有作業揚程加高，或有其他特殊功能需求時，歡迎與本公司洽詢。

※為求產品之精進，本公司保有本型錄相關內容之變更權力，變更時未能一一通知，敬請見諒。

※If you have any special requirements or questions, please don't hesitate to contact us.

※We reserve these data right to improve without prior notice.



## 電動堆高機 Electric Forklift



- ※無害氣、噪音污染。
- ※低設備成本，高工作效益。
- ※可調式鍛造鋼貨叉，適用於單面或雙面棧板作業。
- ※採用歐美進口高品質：驅動主機、液壓系統、微電腦無段式速度控制系統等原裝零組件，品質穩定。
- ※配備歐洲名牌原裝大型工業電瓶，可作長時間的連續作業。

- ※DC-24V power, no gas and noise pollution.
- ※ Compact, easy operate and maintenance.
- ※ Robust construction with high quality driving, lifting and speed controlling components, to provide the best performance.
- ※ Equipped with traction batteries and automatic power charger.
- ※ Low cost and high economic efficiency.

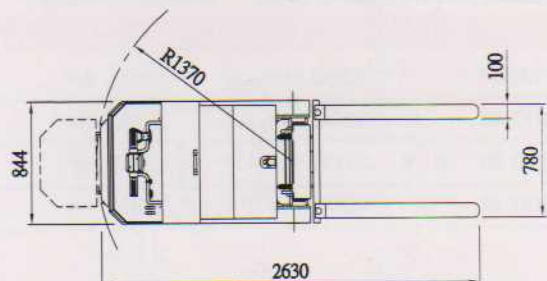
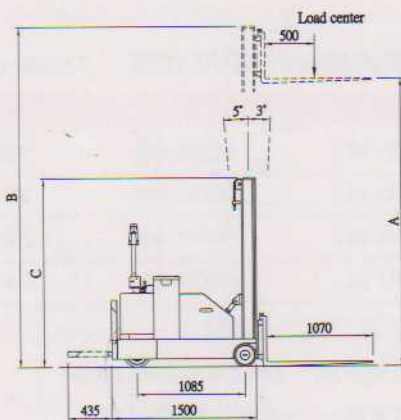



## 規格說明 Specifications

型式	Model		LPF-12CW	LPF-15CW
負載能力	Loading capacity	kg.	1200	1500
動力源	Power source		DC-24V	DC-24V
行走馬達	Driving motor	kw.	1.3	1.6
昇降馬達	Lifting motor	kw.	3.0	3.0
空載行走速度	Empty driving speed	km/h	6.0	6.0
負載行走速度	Loaded driving speed	km/h	5.5	5.5
空載爬坡能力	Empty gradient	%	8	8
負載爬坡能力	Loaded gradient	%	6	6
操作方式	Operating type		立乘式 Stand ride	立乘式 Stand ride
機台全長	Overall length	mm.	2630	2830
A 揚昇高度	Lifting height	mm.	2750	2750
B 全昇機高	Extended height	mm.	3250	3250
C 全降機高	Lowered height	mm.	1925	1925
貨叉傾斜角度	Fork tilting angle	degree	前傾 Forward 3° / 後仰 Backward 5°	
迴轉半徑	Turning radius	mm.	1370	1570
煞車器	Brake		電磁式 Electric	電磁式 Electric
行走控制器	Driving controller		微電腦無段式 Transistor	微電腦無段式 Transistor
驅動輪	Driving wheel	mm.	270 / 90	270 / 90
負載輪	Loading wheels	mm.	230 / 70	230 / 70
電瓶	Battery	Ah/5hr.	180	180
電瓶重量	Battery weight	kg.	215	215
機台重量	Weight with battery	kg.	1700	1950
充電機	Power charger		DC-24V / 30A	DC-24V / 30A

### 雙節式桅桿行程尺寸表 Duplex mast

A 揚昇高度	B 全昇機高	C 全降機高
2750 st.	3250 mm.	1925 mm.
3000 st.	3500 mm.	2050 mm.
3250 st.	3750 mm.	2175 mm.
3500 st.	4000 mm.	2300 mm.

### 參節式桅桿行程尺寸表 Triplex mast

A 揚昇高度	B 全昇機高	C 全降機高
4000 st.	4500 mm.	1925 mm.
4500 st.	5000 mm.	2080 mm.
5000 st.	5500 mm.	2250 mm.
5500 st.	6000 mm.	2400 mm.

※為配合特殊作業功能要求，如有作業場程加高，或有其他特殊功能需求時，歡迎與本公司洽詢。

※為求產品之精進，本公司保有本型錄相關內容之變更權力，變更時未能一一通知，敬請見諒。

※If you have any special requirements or questions, please don't hesitate to contact us.

※We reserve these data right to improve without prior notice.



# 自走式電動堆高機

## Electric Pallet Stacker



- ※無害氣、噪音污染。
- ※車體精巧、省作業空間。
- ※安全、易操作、工作效益高。
- ※採用歐美進口高品質：驅動主機、液壓系統、微電腦無段式速度控制系統等原裝零組件，品質穩定。
- ※獨特的液壓式驅動主機懸吊設計，對地摩擦力穩定，能源效率更高。
- ※配備歐洲名牌原裝大型工業電瓶，可作長時間的連續作業。

- ※DC-24V power, no gas and noise pollution.
- ※Compact, easy operate and maintenance.
- ※Robust construction with high quality driving, lifting and speed controlling components, to provide the best performance.
- ※Five points wheels touch to the ground, safety and stability in driving.
- ※Equipped with traction batteries and automatic power charger.
- ※Low cost and high economic efficiency.

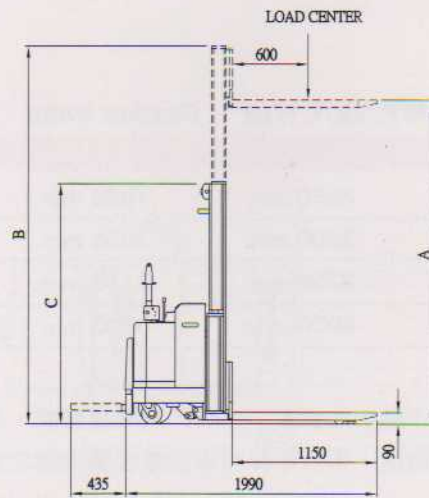
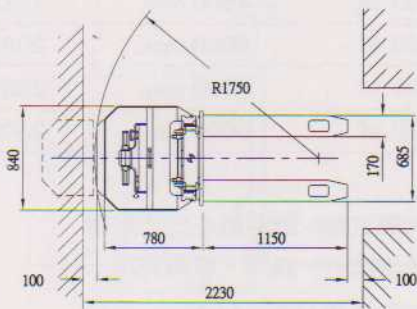



## 規格說明 Specifications

型式	Model		LPS-16S
負載能力	Loading capacity	kg.	1600
動力源	Power source		DC-24V
行走馬達	Driving motor	kw.	1.5
昇降馬達	Lifting motor	kw.	3
空載行走速度	Empty driving speed	km/h	6
負載行走速度	Loaded driving speed	km/h	5.5
空載爬坡能力	Empty gradient	%	12
負載爬坡能力	Loaded gradient	%	8
操作方式	Operating type		立乘式 Stand ride
A 揚昇高度	Lifting height	mm.	2750
B 全昇機高	Extended height	mm.	3250
C 全降機高	Lowered height	mm.	1925
迴轉半徑	Turning radius	mm.	1750
直角通道寬	Angle stacking aisle	mm.	2210
煞車器	Brake		電磁式 Electric
行走控制器	Driving controller		微電腦無段式 Transistor
驅動輪	Driving wheel	mm.	230 / 75
負載輪	Loading wheels	mm.	80 / 70
輔助輪	Auxiliary wheels	mm.	150 / 50
電瓶	Battery Ah/5hr.		180
電瓶重量	Battery weight	kg.	215
機台重量	Weight (with battery)	kg.	1180
充電機	Power charger		DC-24V / 30A

### 雙節式桅桿行程尺寸表 Duplex mast

A 揚昇高度	B 全昇機高	C 全降機高
2750 st.	3250 mm.	1925 mm.
3000 st.	3500 mm.	2050 mm.
3250 st.	3750 mm.	2175 mm.
3500 st.	4000 mm.	2300 mm.

### 參節式桅桿行程尺寸表 Triplex mast

A 揚昇高度	B 全昇機高	C 全降機高
4000 st.	4500 mm.	1925 mm.
4500 st.	5000 mm.	2080 mm.
5000 st.	5500 mm.	2250 mm.
5500 st.	6000 mm.	2400 mm.

※為配合特殊作業功能要求，本公司另提供有：寬腿型、貨櫃型、貨叉調整、底盤揚昇及作業揚程加高等機型，倘有特殊需求時，歡迎與本公司洽詢。

※為求產品之精進，本公司保有本型錄相關內容之變更權力，變更時未能一一通知，敬請見諒。

※If you have any special requirements or questions, please don't hesitate to contact us.

※We reserve these data right to improve without prior notice.



## 自走式電動堆高機 Electric Pallet Stacker



- ※無害氣、噪音污染。
- ※車體精巧、省作業空間。
- ※安全、易操作、工作效益高。
- ※採用歐美進口高品質：驅動主機、液壓系統、速度控制系統等原裝零組件，品質穩定。
- ※彈簧式驅動主機懸吊設計，對地磨擦力充足，行駛平穩，能源效率更高。
- ※DC-24V power, no gas and no noise pollution.
- ※Compact, easy operate and easy maintenance.
- ※Robust construction with high quality driving, lifting and speed controlling components, to provide the best performance.
- ※Five points wheels touch to the ground, safety and stability in driving.
- ※Equipped the deep cycle batteries and automatic power charger.
- ※Low cost and high economic efficiency.

### 規格說明 Specifications

型式	Model		LPS-10E	LPS-15E
負載能力	Loading capacity	kg.	1000	1500
A 揚昇高度	Lifting height	mm.	2750	2750
迴轉半徑	Turning radius	mm.	1550	1660
直角通道寬	Angle stacking aisle	mm.	1995	2150
行走控制器	Driving controller	電子三段式 Resistor		
電瓶	Battery	Ah/5hr.	100	100
電瓶重量	Battery weight	kg.	80	80
機台重量	Weight (with battery)	kg.	690	810
充電機	Power charger	DC-24V / 20A		

### 雙節式桅桿行程尺寸表 Duplex mast

A 揚昇高度	B 全昇機高	C 全降機高
2750 st.	3250 mm.	1925 mm.
3000 st.	3500 mm.	2050 mm.
3250 st.	3750 mm.	2175 mm.

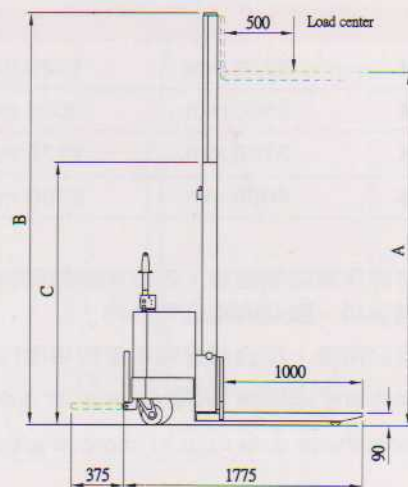
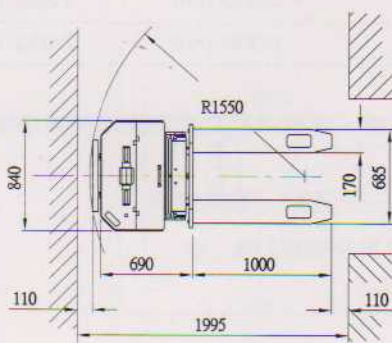



# 手拉式電動堆高機

## Semi-electric Pallet Stacker



- ※ 低成本、高效益。
- ※ 車體精巧、操作容易。
- ※ 配備可移動式貨叉，適用於各式作業。
- ※ 配備內置式充電機，充電作業更方便。

- ※ Low cost, high efficiency.
- ※ Electric lift, manually propelled.
- ※ Adjustable forks suit for various handling.
- ※ Equipped with on-board battery charger.

### 規格說明 Specifications

型式	Model	D-1000	
負載能力	Loading capacity	kg.	1000
揚昇高度	Lifting height	mm.	2500
全昇機高	Extended height	mm.	3050
全降機高	Lowered height	mm.	1800
貨叉長度	Fork length	mm.	900
電瓶	Battery	Ah/20hr.	120
電瓶重量	Battery weight	kg.	25
機台重量	Weight (with battery)	kg.	320
充電機	Power charger	DC-12V / 10A	

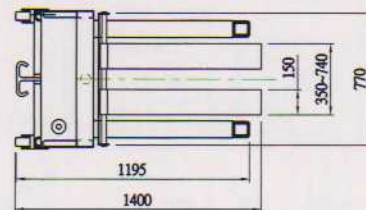
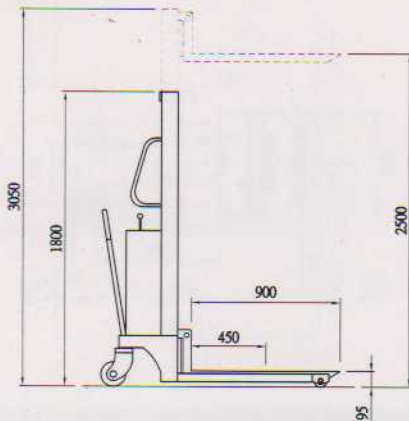

## 自走式電動拖板車 Electric Pallet Truck



- ※無害氣、噪音污染。
- ※車體精巧、省作業空間。
- ※易操作、好保養、工作效益高。
- ※採用歐美進口高品質：驅動主機、液壓系統、微電腦無段式速度控制系統等原裝零組件，品質穩定。
- ※獨特的液壓式驅動主機懸吊設計，對地摩擦力穩定，能源效率更高。
- ※配備歐洲名牌原裝大型工業電瓶，可作長時間的連續作業。

### 規格說明 Specifications

型式	Model		LPT-22S	LPT-30S
負載能力	Loading capacity	kg.	2200	3000
動力源	Power source		DC-24V	DC-24V
行走馬達	Driving motor	kw.	1.0	1.5
昇降馬達	Lifting motor	kw.	2.0	2.0
空載行走速度	Empty driving speed	km/h	6.0	6.0
負載行走速度	Loaded driving speed	km/h	5.5	5.5
空載爬坡能力	Empty gradient	%	16	16
負載爬坡能力	Loaded gradient	%	8	8
操作方式	Operating type		立乘式 Stand ride	立乘式 Stand ride
揚昇高度	Lifting height	mm.	205	205
全昇機高	Extended height	mm.	1310	1310
全降機高	Lowered height	mm.	1310	1310
迴轉半徑	Turning radius	mm.	1655	1655
直角通道寬	Angle stacking aisle	mm.	2400	2040
煞車器	Brake		電磁式 Electric	電磁式 Electric
行走控制器	Driving controller		微電腦無段式 Transistor	微電腦無段式 Transistor
驅動輪	Driving wheel	mm.	230 / 75	230 / 75
負載輪	Loading wheels	mm.	80 / 70	80 / 70
輔助輪	Auxiliary wheels	mm.	150 / 50	150 / 50
電瓶	Battery	Ah/5hr.	160	180
電瓶重量	Battery weight	kg.	180	215
機台重量	Weight with battery	kg.	680	720
充電機	Power charger		DC-24V / 25A	DC-24V / 30A

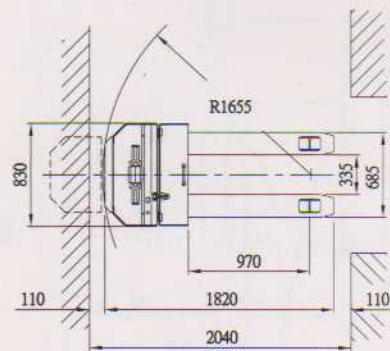
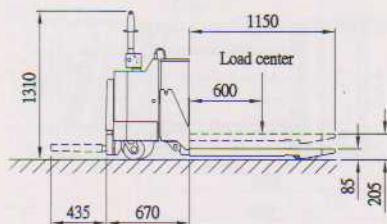



# 自走式電動拖板車

## Electric Pallet Truck



- ※無害氣、噪音污染。
- ※車體精巧、省作業空間。
- ※易操作、好保養、工作效益高。
- ※採用歐美進口高品質：驅動主機、液壓系統、速度控制系統等原裝零組件，品質穩定。
- ※驅動主機懸吊五輪式設計，對地摩擦力充足，行駛平穩，能源效率高。
- ※ DC-24V power, no gas and no noise pollution.
- ※ Compact, easy operate and maintenance.
- ※ Robust construction with high quality driving, lifting and speed controlling components, to provide the best performance.
- ※ Five points wheels touch to the ground, safety and stability in driving.
- ※ Equipped the deep cycle batteries and automatic power charger.
- ※ Low cost and high economic efficiency.

### 規格說明 Specifications

型式	Model	LPT-20E	
負載能力	Loading capacity	kg .	2000
揚昇高度	Lifting height	mm.	205
迴轉半徑	Turning radius	mm.	1655
直角通道寬	Angle stacking aisle	mm.	2040
行走控制器	Driving controller	電子三段式 Resistor	
電瓶	Battery	Ah/5hr.	100
電瓶重量	Battery weight	kg .	80
機台重量	Weight (with battery)	kg .	450
充電機	Power charger	DC-24V / 20A	

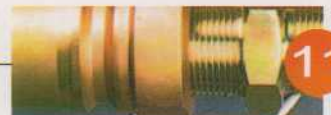
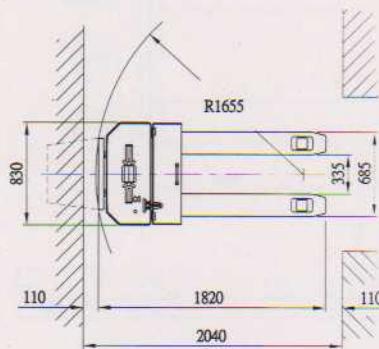
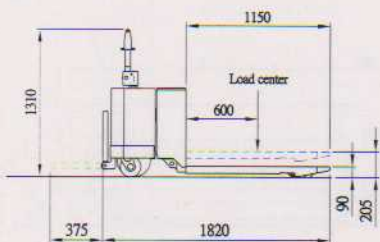

## 手拉式油壓拖板車 Hand Pallet Truck



- ※外型美觀、結構剛性強、輕巧耐用。
- ※一體成型液壓缸體設計，耐用不漏油。
- ※插件式液壓閥門設計，保養維修方便。
- ※三段式定位下降控制，操作輕便省力。
- ※前導輪設計，方便雙面棧板進出作業。
- ※全車烤漆、美觀不易脫漆。
- ※另有其他規格品，歡迎洽詢。

- ※ Robust construction, with welded throughout steel frame and reinforced high tensile steel forks.
- ※ Rugged hydraulic system proven by LIFTEK Products.
- ※ The handle lever has a 3 position control: LIFT-NEUTRAL-LOWER
- ※ Standard type have additional climber wheels, facilitating pallet handling.
- ※ Special specifications upon request.

### 規格說明 Specifications

型式	Model		CBY-23M	CBY-23S	CBY-23L
負載能力	Loading capacity	kg .	2000	2000	2000
揚昇高度	Lifting height	mm.	85-200	85-200	85-200
L 貨叉長度	Fork length	mm.	900	1150	1220
W 貨叉外寬	Overall width	mm.	520	520	685
貨叉寬度	Fork width	mm.	160	160	160
負載輪	Loading Wheels	mm.	φ78 / 94	φ78 / 94	φ78 / 94
前導輪	Climber wheels	mm.	φ44 / 30	φ44 / 30	φ44 / 30
轉向輪	Steering wheels	mm.	φ180 / 50	φ180 / 50	φ180 / 50
機台重量	Weight	kg .	79	84	91

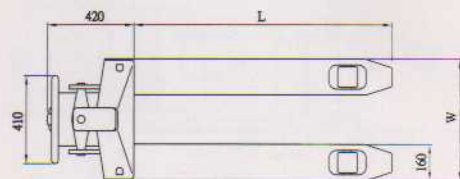
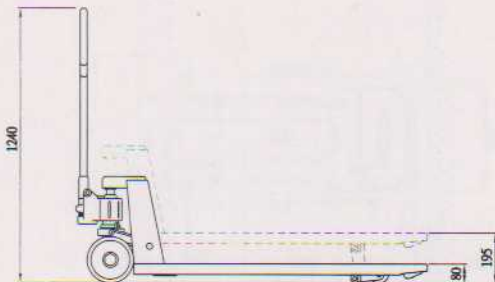



# 手動堆高機

## Manual Pallet Stacker



- ※ 成本低、效益高。
- ※ 安全、耐用、省力、輕巧。
- ※ 手動油壓昇降控制，可作微量調整。

※ The most economic way to handle and stack things.

※ Lifting and lowering by manual hydraulic operation with micro-adjustment features.

### 規格說明 Specifications

型式	Model	H-1000	
負載能力	Loading capacity	kg .	1000
揚昇高度	Lifting height	mm.	1500
機台長度	Overall length	mm.	1350
機台寬度	Overall width	mm.	710
機台高度	Lowered height	mm.	1900
貨叉長度	Fork length	mm.	900
貨叉外寬	Fork overall width	mm.	680
負載輪	Loading wheels	mm.	φ 80 / 70
轉向輪	Turning wheels	mm.	φ 180 / 50
機台重量	Weight	kg .	180

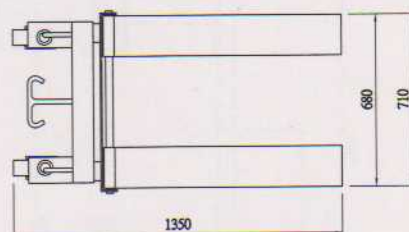
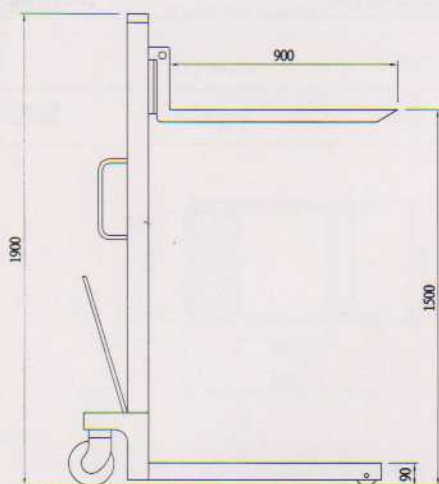

# 高空取料機

## Mobile Hydraulic Picker



- ※作業高度：4M.
- ※低成本、高效益。
- ※操作簡易安全，移動輕巧便利。
- ※廠房、倉庫、大型超商賣場，物料架貨物存取的最佳幫手。
- ※ Working height : 4000mm.
- ※ Low cost, high economic effects.
- ※ Easy moving and operating.
- ※ The best equipment for materials picking and handling.

### 規格說明 Specifications

型式	Model	DLP-200	
負載能力	Capacity	kg .	200
揚昇高度	Loading height	mm.	2500
作業高度	Working height	mm.	4000
台面長度	Platform length	mm.	600
台面寬度	Platform width	mm.	600
輪子	Wheels	mm.	φ 180 / 50
電瓶	Battery	Ah/20hr.	120
電瓶重量	Battery Weight	kg .	20
機台重量	Weight with battery	kg .	240
充電機	Power charger	DC-12V / 10A	

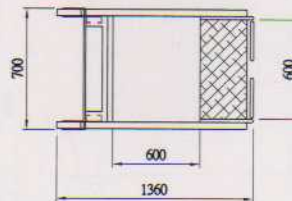
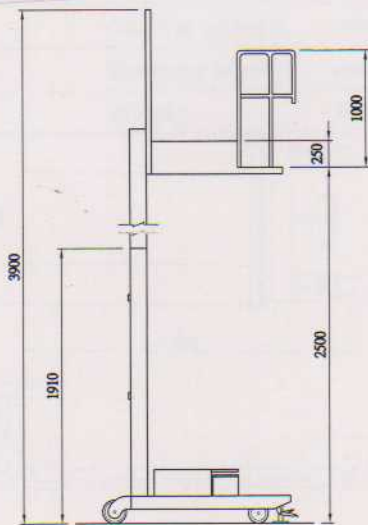



# 手推式升降平台車

## Pushed Lifting Table



- ※低成本、高效益。
- ※輕巧、方便、省力、耐用。
- ※全車烤漆，外型美觀。
- ※手動下降速度控制，可作微量調整。
- ※適用於生產線上貨物、模具、加工件等昇降或搬運作業。

- ※Economic & convenient.
- ※Lifting and lowering by manual hydraulic operation with micro-adjustment features.

### 規格說明 Specifications

型式	Model		TF-150	TF-300	TF-350D	TF-500	TF-750
負載能力	Loading capacity	kg .	150	300	350	500	750
A 台面最高高度	Max table height	mm.	740	900	1300	950	1000
B 台面最低高度	Min table height	mm.	210	270	330	290	410
C 台面長度	Table length	mm.	700	815	915	915	1000
D 台面寬度	Table width	mm.	450	500	505	505	513
E 機台長度	Overall length	mm.	820	1060	1100	1100	1280
機台寬度	Overall width	mm.	450	500	505	505	575
F 機台高度	Overall height	mm.	820	960	960	960	980
輪徑	Wheels	mm.	φ100 / 40	φ125 / 40	φ125 / 40	φ125 / 40	φ150 / 40
機台重量	Weight	kg .	34	70	95	84	107

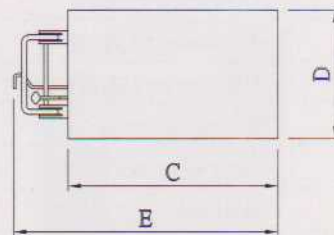
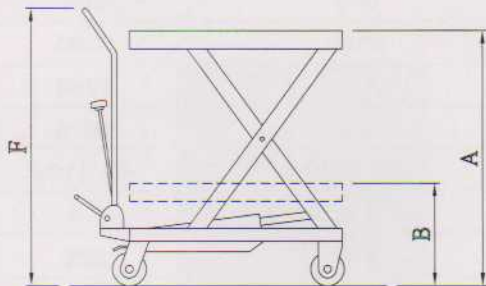



MAWP-8S

## 高空作業台 Mobile Hydraulic Lifter

- ※作業高度：6.5-14M.
- ※採用高強度鋁合金升降桅桿，重量輕、剛性強，可單人操作。
- ※液壓升降速度平穩，安全性高。
- ※附調整水平儀，重心調整簡易確實。
- ※全機高度約2M，方便車載作業及出入電梯。
- ※適用於學校禮堂、飯店大廳或廠房等場所之清潔維修作業。
- ※另有DC-12V動力電源機型，方便室外作業使用。



MAWP-12D

- ※Working height：6.5—14M.
- ※Easy moving and operating.
- ※Safe and convenient.
- ※The best equipment for sky working.
- ※Power：Standard AC-110V or 220V  
Option DC-12V.

### 規格說明 Specifications

型式	Model		MAWP-8S	MAWP-12D
負載能力	Capacity	kg .	125	200
揚昇高度	Lifting height	mm.	8000	12000
作業高度	Working Height	mm.	9800	13800
工作台長度	Working Platform Length	mm.	630	1210
工作台寬度	Working Platform Width	mm.	640	600
機台長度	Overall Length	mm.	1420	1790
機台寬度	Overall Width	mm.	840	890
機台高度	Lowered Height	mm.	2040	2030
延伸長度	Extended Length	mm.	2030	2250
延伸寬度	Extended Width	mm.	1840	2570
動力源	Power Source		AC 110V	AC 110V
昇降馬達	Lifting Motor	kw.	0.75	1.5
機台重量	Weight	kg .	410	825



其他銷售產品  
Other Products



迷你堆高機  
Mini Stacker



手動油桶卸料機  
Manual Drum Unloader



油桶過磅車  
Drum Litter



單層·雙層·三層手推車  
Hand Cart



歐美進口工業電瓶  
Traction Batteries



木棧板·金屬棧板·塑膠棧板  
Pallets



輕量型·中量型·重量型物料架  
Racks



充電機  
Power Charger

製造/Manufacturer

**力富得股份有限公司**  
**LIFTEK CORPORATION.**

宜蘭縣五結鄉(利澤工業區)利工一路二段32號  
No.32, Sec.2, Li Kung 1st Rd.,Li Tse Industrial  
Park, I-Lan Hsien, Taiwan.

Tel:+886-3-990-8128 Fax:+886-3-990-8188

E-mail: liftek@ms39.hinet.net

<http://www.liftek.com.tw>

桃園

Tel:+886-3-3501990 Fax:+886-3-3597550

台中

Tel:+886-4-25672699 Fax:+886-4-25682545

台南

Tel:+886-6-5976033 Fax:+886-6-5976032

