



# QUICK-UP



**A wide range of machines to meet your every need**

- Working heights from 7 to 14 m
- 2 available versions supply-power (AC) or batteries (DC)

**The Quick-Up will follow you on every project**

- Easy to transport on a trailer or van
- Only one person is needed to install a Quick Up
- The light weight enables use on fragile grounds, tiles, carpeting...
- Quick up are extremely compact, they can access the tightest spaces, fit through standard doorways and can be transported in lifts

**Haulotte**   
GROUP

More than lifting



# QUICK-UP 7 / 8 / 9 / 11 / 12 / 13 / 14

PUSH AROUND BOOMS

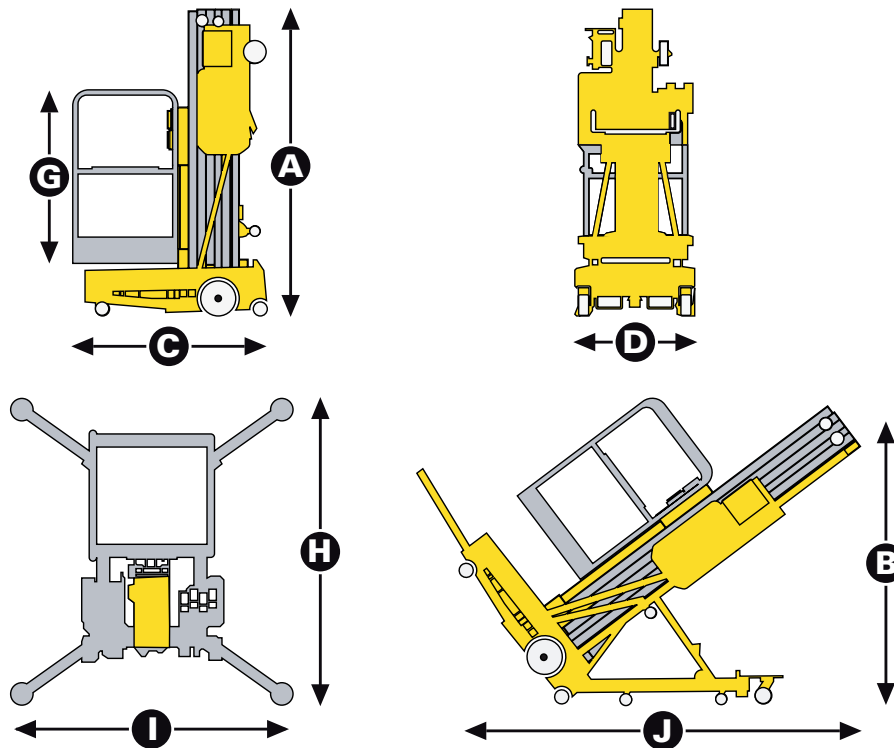

TECHNICAL DATA	QUICK-UP 7	QUICK-UP 8	QUICK-UP 9	QUICK-UP 11	QUICK-UP 12	QUICK-UP 13	QUICK-UP 14
Working height	6.7 m	8.1 m	9.5 m	10.8 m	12.3 m	13.7 m	14.3 m
Platform height	4.7 m	6.1 m	7.5 m	8.8 m	10.3 m	11.7 m	12.3 m
Lift capacity	200 kg	159 kg	159 kg	159 kg	136 kg	136 kg	136 kg
Platform size	0.68 x 0.66 m	0.68 x 0.66 m	0.68 x 0.66 m	0.68 x 0.66 m	0.68 x 0.66 m	0.68 x 0.66 m	0.68 x 0.66 m
<b>C</b> Length	1.22 m	1.28 m	1.28 m	1.34 m	1.4 m	1.47 m	1.42 m
<b>D</b> Width	0.8 m	0.8 m	0.8 m	0.8 m	0.8 m	0.8 m	0.8 m
<b>A</b> Height - stowed	1.78 m	1.98 m	1.98 m	1.98 m	1.98 m	1.98 m	2.8 m
<b>I</b> Width - stabilised	1.55 m	1.55 m	1.55 m	1.55 m	2.06 m	2.34 m	2.33 m
<b>H</b> Length - stabilised	1.75 m	1.75 m	1.75 m	1.75 m	2.26 m	2.7 m	2.58 m
<b>F x G</b> Tilt bar	N/A	N/A	N/A	N/A	N/A	N/A	2.85 x 1.99 m
Energy (AC)	110 or 230 V	110 or 230 V	110 or 230 V	110 or 230 V	110 or 230 V	110 or 230 V	110 or 230 V
Weight (AC)	315 kg	340 kg	360 kg	380 kg	415 kg	455 kg	515 kg
Energy (DC)	12 V	12 V	12 V	12 V	12 V	12 V	12 V
Weight (DC)	357 kg	382 kg	402 kg	422 kg	457 kg	497 kg	557 kg

## STANDARD EQUIPMENT

- Easy to use thanks push button controls
- Emergency control
- Manual platform lowering valve
- Integrated forklift pockets
- Lifting eye
- Non marking wheels
- Harness attachment point
- Lights on control box to confirm stabilizers are set

## OPTIONS AND ACCESSORIES

- Battery version (DC power)