

# HT16 RTJ PRO



## GREAT PRODUCTIVITY & PERFORMANCE

- > Dual load capacity: 250 - 350 kg restricted
- > 4 wheel drive for excellent rough terrain capabilities
- > 4 wheel steer for agile maneuverability
- > Quick & simultaneous movements

## MAXIMIZED TOTAL COST OF OWNERSHIP

- > Haulotte Activ'Screen : on-board configuration & diagnostic interface
- > Easy access to components
- > Haulotte Stop Emission System reduces engine and component use
- > Reduced engine TCO (power <19 kW : no particulate filter)

## OPTIMAL SAFETY

- > Haulotte Activ'Shield Bar prevents crushing risks
- > Haulotte Activ'Lighting System lightens the boom for safe loading in low visibility
- > Smooth & proportional movements for greater precision



# HT16 RTJ PRO

## ROUGH TERRAIN TELESCOPIC BOOMS

### TECHNICAL DATA

#### HT16 RTJ PRO

Working height	16.1 m
Platform height	14.1 m
Horizontal outreach	13 m
Lift capacity	250kg (option: restricted 350kg)
<b>A</b> Length - stowed	9.16 m
<b>B</b> Overall width	2.29 m
<b>C</b> Height - stowed	2.47 m
<b>D</b> Wheelbase	2.35 m
<b>E</b> Ground clearance	33 cm
<b>F</b> x <b>G</b> Platform size	1.83m x 0.76m
<b>H</b> Storage / transport length	6.68 m
Storage / transport height	3.06 m
Vertical jib rotation	133° (+68°/ -65°)
Turntable rotation	360° continuous
Tailswing	93 cm
Tilt	5 °
Drive speed	5.2 km/h
Gradeability	45 %
Turning radius - outside	3.6 m
Tyres - solid rough terrain	850 x 340 mm
Engine	Kubota 18.5kW (Stage 5 & NRC)
Weight	7 930kg

### STANDARD EQUIPMENT

- > Haulotte Activ' Shield bar: anti-entrapment system
- > Haulotte Activ' Lighting System: improved visibility
- > Haulotte Activ' Screen: on-board diagnostics
- > Haulotte Stop Emission System: automatically turns the engine off & on
- > 4 wheel drive
- > 4 wheel steer
- > Oscillating axle
- > Differential : permanent limited slip & operator controlled locking rear
- > Smooth & proportional movements
- > Universal telematic plug
- > Up to 4 simultaneous movements
- > Cured-on solid tires
- > Swing out engine tray
- > Upper control box protection and tool tray
- > Sound and light alarm for tilt and load
- > Motion alarm and rotating beacon

### OPTIONS AND ACCESSORIES

- > Dual load basket capacity 250 - 350kg (restricted envelope)
- > Large platform 2,44 x 0,91m
- > Swing door entry gate
- > Power to platform (plug in basket)
- > Hydraulic generators 3,5kw or 6,5kW
- > Glazier pack
- > Pipe rack kit
- > Air-line to platform
- > Dual USB plug in basket
- > Non-marking tires
- > Hydraulic oil cooler
- > Cold weather package

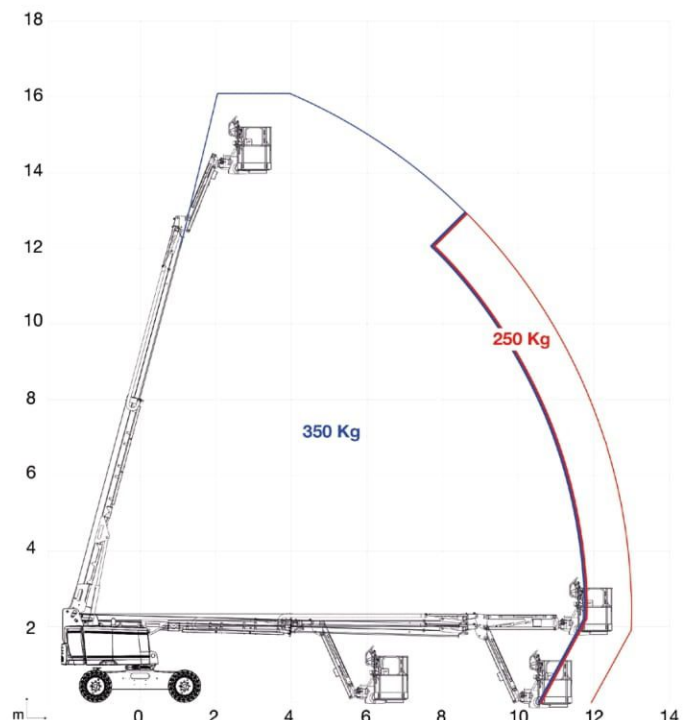
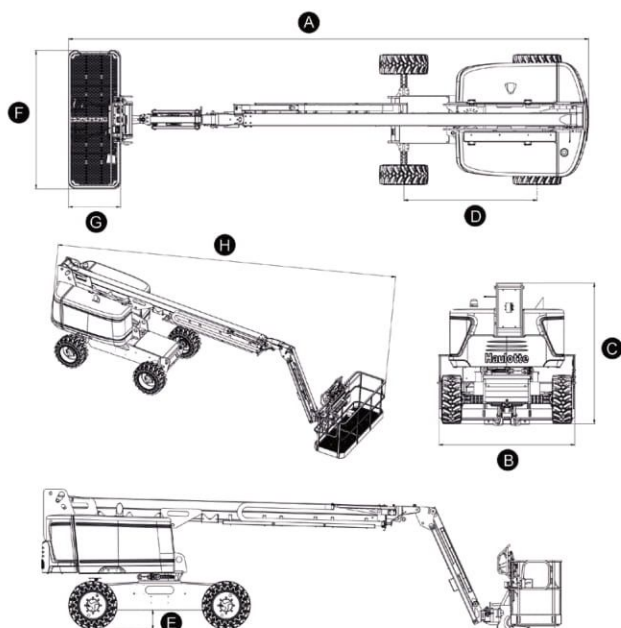

**WILAN**  
Merchandising Phils., Inc

**MANILA OFFICE:**  
460-B Quirino Highway Brgy. Talipapa, Quezon City  
Sales Tel : (02) 8930.1960 / 8939.6652 / 8703.3164  
Service Tel : (02) 8332.9092  
Email: sales@wilan.com.ph  
Website: www.wilan.com.ph

**CEBU OFFICE:**  
Door 2 Rafanan Bldg. Lopez Jaena St.  
Brgy. Subangdaku, Mandaue City Cebu  
Tel : (032) 272.2891  
(032) 272.8166  
Email: cebusales@wilan.com.ph