



Performance & Productivity

- Best horizontal outreach of 22,2m
- Homogenous and fluid working envelope
- Outstanding RT capacities
- Dual load 230-350 kg (option)

Safety & Comfort

- Haulotte Activ' Lighting system safe load (option)
- Unmatched comfort & smoothness in elevation thanks to a unique regulation system of boom movements
- Most rigid boom
- Haulotte Activ' Shield™ Bar (option)

Cost efficiency

- Haulotte Activ' Screen (on board diagnostic)
- Haulotte Stop Emission System which automatically turns off & on the engine
- Easy access to all components
- Modular basket quick and easy to repair

Haulotte



HT26 RT 0

TELESCOPIC BOOM



TECHNICAL DATA

HT26 RT 0

4WD-2WS

Working height	26.4 m
Platform height	24.4 m
Horizontal outreach	22.2 m
Below ground reach	1.5 m
Lift capacity	230 kg (option 350 kg)
F x G Platform size	2,44 x 0,91
A Length - stowed	11.55 m
H Length - storage	11.55 m
B Width	2.48 m
C Height - stowed	2.85 m
I Height - storage	2.85 m
Platform rotation	180° (+90°/-90°)
Boom rotation angle	84.5° (+74.5° / -10°)
Turntable rotation	360° continuous
Tailswing	150 cm
Wheelbase	2,8
D Ground clearance	48 cm
E Tilt	4 °
Drive speed	0.5 - 5 km/h
Gradeability	45 %
Turning radius - outside	6,55
Tires - solid rough terrain	1025x365"
Fuel tank	120 l
Engine	Kubota Tier 3 - 49,3kW & Kubota Tier 4f - 53 kW
Weight	17400 kg

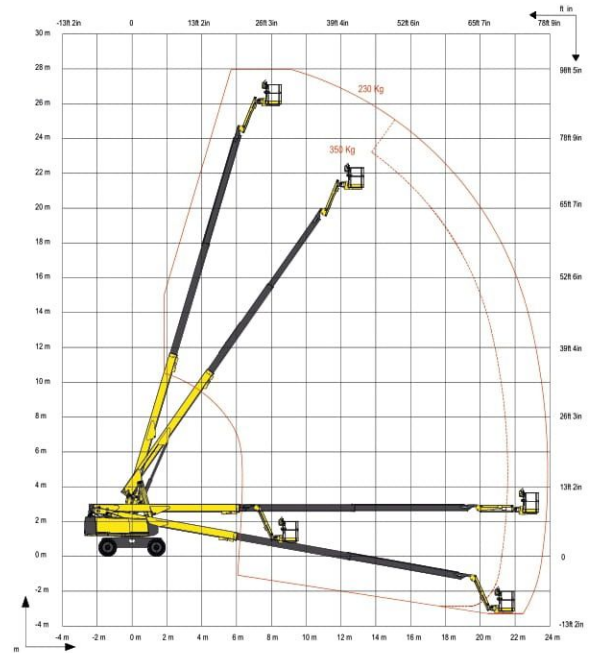

STANDARD EQUIPMENT

- Haulotte Activ' Screen : on-board diagnostic
- Haulotte Stop Emission System
- Universal telematics pug
- Swing out engine tray for easy maintenance
- Safe to use in winds up to 45 km/h
- Travel alarm
- Tilt / load alarm and light
- Upper control box protection cover and tool tray made of ultra resistant composite
- Drop bar entry gate
- Large modular basket 2,44 x 0,91m
- Front oscillating axle
- Automatic differential wheel lock
- 4 wheels drive / 2 wheels steer
- Smooth proportional and cumulated movements

OPTIONS AND ACCESSORIES

- Haulotte Activ' Lighting System
- Haulotte Activ' Shield™ Bar 2.0
- Dual load 230-350kg
- Lateral swing door entry gate
- Power to platform (230V/110V)
- Hydraulic generator 3,5kW ou 6,5kW
- Air line to platform
- Glazier pack
- Pipe cradle pack
- Working light
- Motion flashing warning light
- Cold weather kit / Arctic weather kit
- Hydraulic oil cooler
- Non marking tires
- Battery circuit breaker
- White diesel

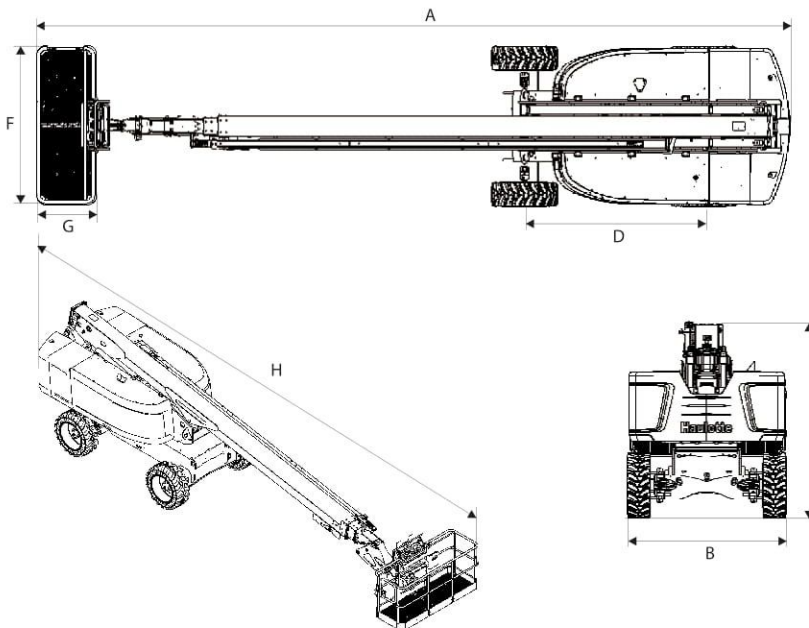

MANILA OFFICE:

460-B Quirino Highway Brgy. Talipapa, Quezon City
 Sales Tel : (02) 8930.1960 / 8939.6652 / 8703.3164
 Service Tel : (02) 8332.9092
 Email: sales@wilan.com.ph
 Website: www.wilan.com.ph

CEBU OFFICE:

Door 2 Rafanan Bldg. Lopez Jaena St.
 Brgy. Subangdaku, Mandaue City Cebu
 Tel : (032) 272.2891
 (032) 272.8166
 Email: cebusales@wilan.com.ph